

DATA SHEET

Product Name Wire-wound Anti-Surge Fixed Resistors

Part Name KNPA Series

File No. DIP-SP-012

Uniroyal Electronics Global Co., Ltd.

88#, Longteng Road, Economic & Technical Development Zone, Kunshan, Jiangsu, China

Tel +86 512 5763 1411 / 22 /33

Email marketing@uni-royal.cn

Manufacture Plant Uniroyal Electronics Industry Co., Ltd.

Aeon Technology Corporation

Royal Electronic Factory (Thailand) Co., Ltd.

Royal Technology (Thailand) Co., Ltd.

1. Scope

- 1.1 This datasheet is the characteristics of Wire-wound Anti-Surge Fixed Resistors manufactured by UNI-ROYAL.
- 1.2 Excellent flame retardant coating
- 1.3 According to IEC 61000-4-5
- 1.4 Applies to electricity meters, home appliance and ballast
- 1.5 Compliant with RoHS directive.
- 1.6 Halogen free requirement.

2. Part No. System

The standard Part No. includes 14 digits with the following explanation:

2.1 Wire-Wound Fixed Resistors type, the 1st to 3rd digits are to indicate the product type and 4th digit is the special feature.

Example: KNPA= Wire-Wound Anti-Surge Fixed Resistors type.

2.2 5th~6th digits:

2.2.1 This is to indicate the wattage or power rating. To dieting the size and the numbers,

The following codes are used; and please refer to the following chart for detail:

W=Normal Size; S=Small Size; U=Extra Small Size; “1”~“G”to denotes“1”~“16”as

Hexadecimal:

1/16W~1/2W (< 1W)

Wattage	1/2	1/3	1/4	1/5	1/6	1/8	1/10	1/16
Normal Size	W2	W3	W4	W5	W6	W8	WA	WG
Small Size	S2	S3	S4	S5	S6	S8	SA	SG

1W~16W ($\geq 1W$)

Wattage	1	2	3	5	7	8	9	10	15
Normal Size	1W	2W	3W	5W	7W	8W	9W	AW	FW
Small Size	1S	2S	3S	5S	7S	8S	9S	AS	FS

2.2.2 For power rating less than 1 watt, the 5th digit will be the letters W, S or U to represent the size required & the 6th digit will be a number or a letter code.

Example: WA=1/10W

2.2.3 For power of 1 watt to 16 watt, the 5th digit will be a number or a letter code and the 6th digit will be the letters of W or S.

Example: AS=10W-S; 3S=3W-S

2.3 The 7th digit is to denote the Resistance Tolerance. The following letter code is to be used for indicating the standard Resistance Tolerance.

F=±1% G=±2% J=±5% K= ±10%

2.4 The 8th to 11th digits is to denote the Resistance Value.

2.4.1 For the standard resistance values of 5% series, the 8th digit is “0”, the 9th & 10th digits are to denote the significant figures of the resistance and the 11th digit is the number of zeros following.;

2.4.2 The following number s and the letter codes are to be used to indicate the number of zeros in the 11th digit:

0=10⁰ 1=10¹ 2=10² 3=10³ 4=10⁴ 5=10⁵
6=10⁶ J=10⁻¹ K=10⁻² L=10⁻³ M=10⁻⁴

2.4.3 The 12th, 13th & 14th digits.

The 12th digit is to denote the Packaging Type with the following codes:

A=Tape/Box (Ammo pack) B=Bulk/Box

T=Tape/Reel P=Tape/Box of PT-26 products

2.4.4 The 13th digit is normally to indicate the Packing Quantity of Tape/Box & Tape/Reel packaging types. The following letter code or number code is to be used for some packing quantities:

A=500pcs 1=1000pcs 2=2000pcs 5=5000pcs

2.4.5 For some items, the 14th digit alone can use to denote special features of additional information with the following codes:

0=NIL P=Panasert type 0=NIL 1=Avisert type 1 2=Avisert type 2
3=Avisert type 3

3. Ordering Procedure

(Example: KNPA 3WS ±5% 12Ω T/B-1000)

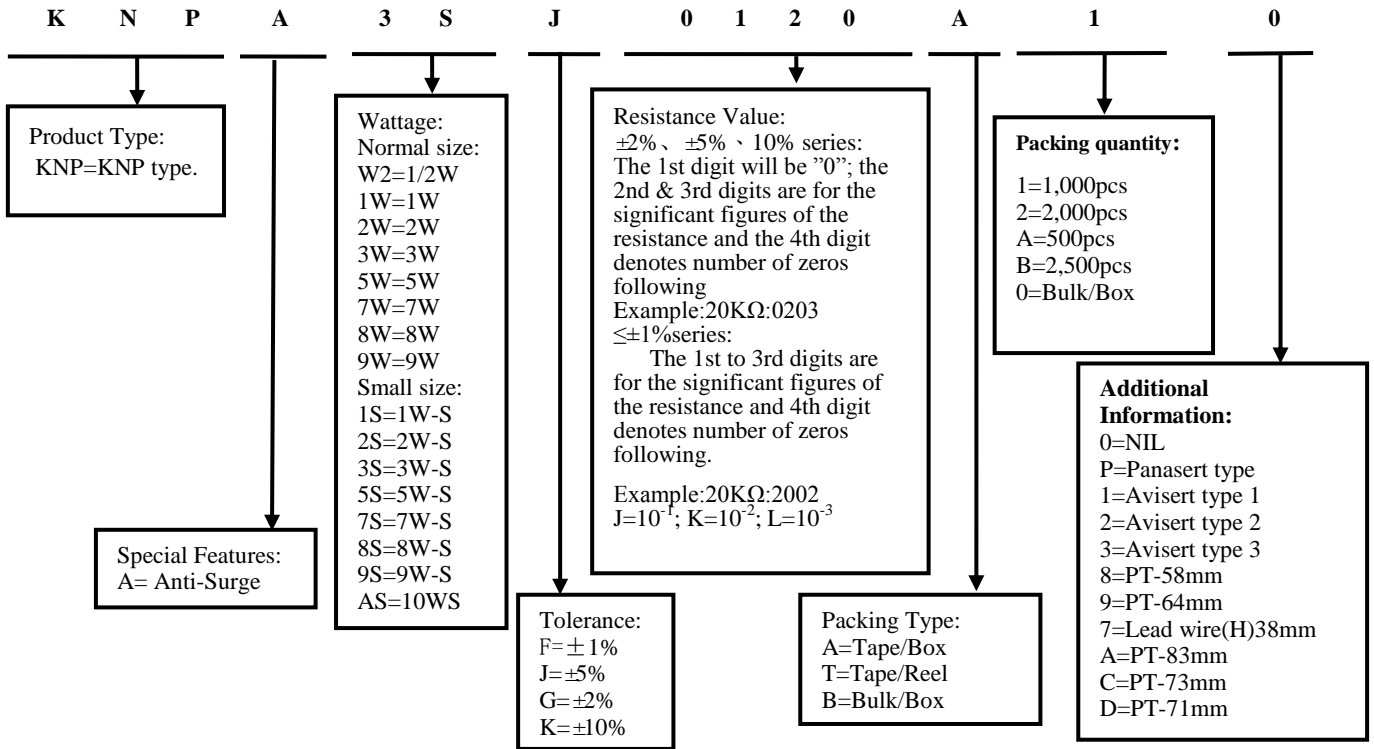

4. Color Code

Resistors shall be marked with color coding
Colors shall be in accordance with JIS C 0802
≥ ±2% Series

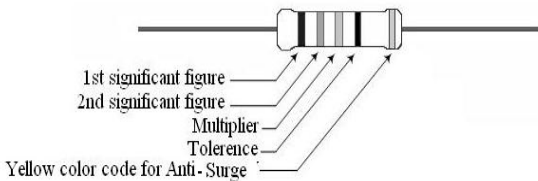

1st Band	2nd Band	3rd Band	4th Band	5th Band
Black = 0	Black = 0	Black = Multiply by 1 (10 ⁰)	Red = ±2%	Yellow
Brown = 1	Brown = 1	Brown = Multiply by 10 (10 ¹)	Gold = ±5%	
Red = 2	Red = 2	Red = Multiply by 100 (10 ²)	Silver = ±10%	
Orange = 3	Orange = 3	Orange = Multiply by 1,000 (10 ³)		
Yellow = 4	Yellow = 4	Yellow = Multiply by 10,000 (10 ⁴)		
Green = 5	Green = 5	Green = Multiply by 100,000 (10 ⁵)		
Blue = 6	Blue = 6	Blue = Multiply by 1,000,000 (10 ⁶)		
Violet = 7	Violet = 7	Violet = Multiply by 10,000,000 (10 ⁷)		
Gray = 8	Gray = 8	Gold = Multiply by 0.1 (10 ⁻¹)		
White = 9	White = 9	Silver = Multiply by 0.01 (10 ⁻²)		

± 1% Series

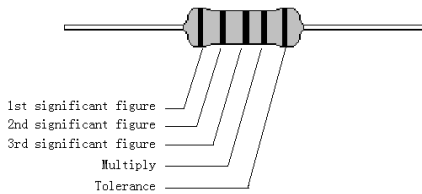

1st Band	2nd Band	3rd Band	4th Band	5th Band
Black = 0	Black = 0	Black = 0	Black = Multiply by 1 (10 ⁰)	Brown = ±1%
Brown = 1	Brown = 1	Brown = 1	Brown = Multiply by 10 (10 ¹)	
Red = 2	Red = 2	Red = 2	Red = Multiply by 100 (10 ²)	
Orange = 3	Orange = 3	Orange = 3	Orange = Multiply by 1,000 (10 ³)	
Yellow = 4	Yellow = 4	Yellow = 4	Yellow = Multiply by 10,000 (10 ⁴)	
Green = 5	Green = 5	Green = 5	Green = Multiply by 100,000 (10 ⁵)	
Blue = 6	Blue = 6	Blue = 6	Blue = Multiply by 1,000,000 (10 ⁶)	
Violet = 7	Violet = 7	Violet = 7	Violet = Multiply by 10,000,000 (10 ⁷)	
Gray = 8	Gray = 8	Gray = 8	Gold = Multiply by 0.1 (10 ⁻¹)	
White = 9	White = 9	White = 9	Silver = Multiply by 0.01 (10 ⁻²)	

4.3 Label:

Label shall be marked with following items:

- (1) Type and style
- (2) Nominal resistance
- (3) Resistance tolerance
- (4) Quantity
- (5) Lot number
- (6) PPM

Example:

Wire-wound Anti-Surge Fixed Resistors	
WATT : 8W	VAL: 22Ω
Q'TY: 25	TOL: 5%
LOT: 7021528	PPM:

5. Ratings & Dimension

5.1 Dimension:

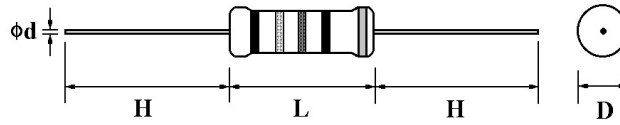

Type	Dimension(mm)					Resistance Range	Tolerance
	D±1	L±1	d±0.05	H±3	PT		
KNPA 1/2W,1WS	3.5	9.5	0.54	28	52	10Ω~820Ω	±1% ±2% ±5% ±10%
KNPA 1W,2WS	4.5	11.5	0.70	25	52	10Ω~1.2KΩ	
KNPA 2W,3WS	5.5	15.5	0.70	28	64	10Ω~3.0KΩ	
KNPA 3W,5WS	6.5	17.5	0.75	28	64	10Ω~3.9KΩ	
KNPA 5W,7WS	8.5	24.5	0.75	38	90	10Ω~5.6KΩ	
KNPA 7W,8WS	8.5	29.5	0.75	38	B/B	10Ω~8.2KΩ	
KNPA 8W,9WS	8.5	39.5	1.00	38	B/B	10Ω~10KΩ	
KNPA 9W,AS	8.5	52.5	1.00	38	B/B	10Ω~15KΩ	

6. Derating Curve

Resistors shall have a power rating based on continuous load operation at an ambient temperature from -55°C to 70°C. For temperature in excess of 70°C, the load shall be derate as shown in figure 1

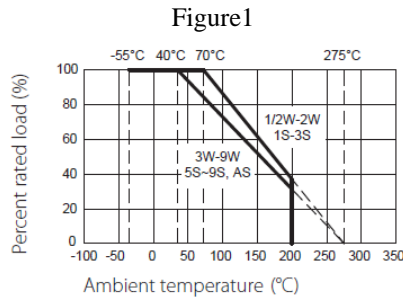

6.1 Voltage rating:

Resistors shall have a rated direct-current (DC) continuous working voltage or an approximate sine-wave root-mean-square (RMS) alternating-current (AC) continuous working voltage at commercial-line frequency and waveform corresponding to the power rating, as determined from the following formula:

$$RCWV = \sqrt{P \times R}$$

Where: RCWV = rated dc or RMS ac continuous working voltage at commercial-line frequency and waveform (VOLT.)

P = power rating (WATT.)

R= nominal resistance (OHM)

7. Pulses Energy Curve

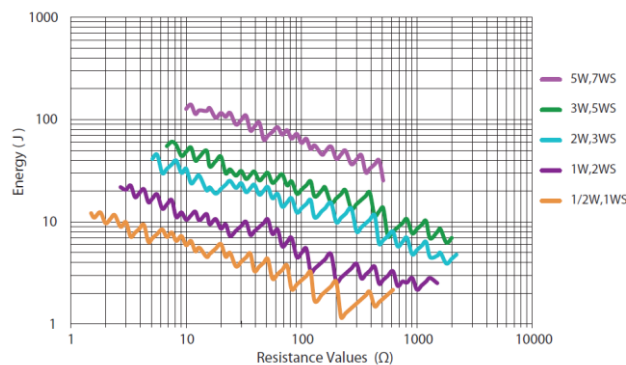

8. 1.2/50us Pulses Voltage Curve

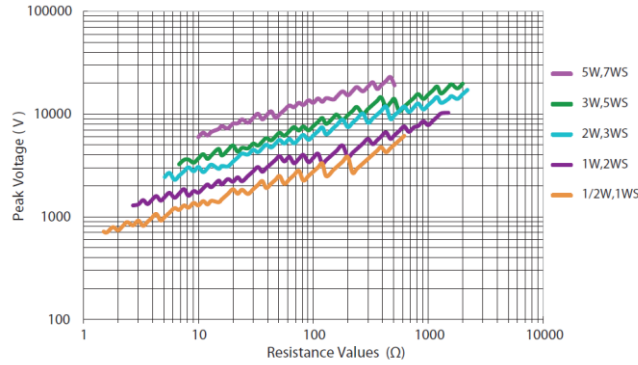

9. Structure

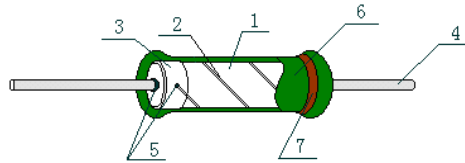

No.	Name	Raw materials
1	Basic body	Rod Type Ceramics
2	Resistor	Alloy
3	End cap	Steel (Tin Plated iron Surface)
4	Lead wire	Tin solder coated copper wire
5	Joint	By welding
6	Coating	Normal size & Insulated Non-Flame Paint Color: Deep Green (Normal size) Light Green (small size)
7	Marking	Epoxy Resin

10. Performance Specification

Characteristic	Limits	Test Methods (GB/T5729&JIS-C-5201&IEC60115-1)
Temperature Coefficient	±200PPM/°C	4.8 Natural resistance changes per temp. Degree centigrade $\frac{R_2 - R_1}{R_1(t_2 - t_1)} \times 10^6 \text{ (PPM/°C)}$ R ₁ : Resistance Value at room temperature (t ₁) ; R ₂ : Resistance at test temperature (t ₂) t ₁ : +25 °C or specified room temperature t ₂ : Test temperature (-55 °C or 125 °C)
Short-Time Overload	Resistance change rate must be in ±(2%+0.05Ω)Max , and no mechanical damage.	4.13 Permanent resistance change after the application of a potential of 2.5 times RCWV or Max.Overload Votage whichever less for 5 seconds.
Terminal strength	No evidence of mechanical damage	4.16 Direct load: Resistance to a 2.5 kg direct load for 10 seconds in the direction of the longitudinal axis of the terminal leads. Twist test: Terminal leads shall be bent through 90° at a point of about 6mm from the body of the resistor and shall be rotated through 360° about the original axis of the bent terminal in alternating direction for a total of 3 rotations.

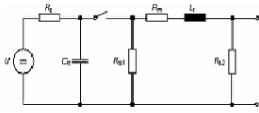
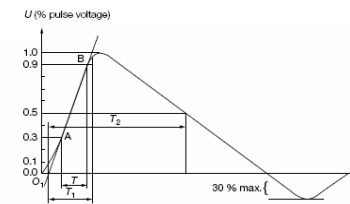
Resistance to soldering heat	Resistance change rate must be in $\pm (1\%+0.05\Omega)$, and no mechanical damage.	4.18 Permanent resistance change when leads immersed to a point 2.0-2.5mm from the body in $260^{\circ}\text{C}\pm 5^{\circ}\text{C}$ solder for 10 ± 1 seconds.
Solderability	95% Coverage Min.	4.17 The area covered with a new, smooth, clean, shiny and continuous surface free from concentrated pinholes. Temperature of solder: $245^{\circ}\text{C}\pm 3^{\circ}\text{C}$ Dwell time in solder: 2~3seconds.
Rapid change of temperature	Resistance change rate must be in $\pm(2\%+0.05\Omega)$, and no mechanical damage.	4.19 30 min at -55°C and 30 min at 155°C ; 100 cycles.
Humidity (steady state)	Resistance change rate must be in $\pm (2\%+0.05\Omega)$, and no mechanical damage.	4.24 Temporary resistance change after 240 hours exposure in a humidity test chamber controlled at $40\pm 2^{\circ}\text{C}$ and 90-95% relative humidity,
Load life in humidity	Resistance change rate must be in $\pm(5\%+0.05\Omega)$, and no mechanical damage.	7.9 Resistance change after 1000 hours (1.5hours “ON” , 0.5hours “OFF”) at RCWV or Max.Working Voltage whichever less in a humidity test chamber controlled at $40\pm 2^{\circ}\text{C}$ and $93\% \pm 3\% \text{RH}$.
Surge Immunity	Resistance change rate is: $\pm(5\%+0.05\Omega)$ Max	Surge voltage as per the 1.2 $\mu\text{s}/50 \mu\text{s}$ exponential open circuit voltage waveform according to IEC 61000-4-5 standard as shown below:   Front time: $T_1 = 1.67 \times T = 1.2 \mu\text{s} \pm 30\%$ Time to half-value: $T_2 = 50 \mu\text{s} \pm 20\%$
Resistance to solvent	No deterioration of protective coatings & markings	4.29 Specimens shall be immersed in a bath of trichloroethylene completely for 3 min. With ultrasonic
Load life	Resistance change rate must be in $\pm(5\%+0.05\Omega)$, and no mechanical damage.	4.25.1 Permanent Resistance change after 1000 hours operating at RCWV or Max.Working Voltage whichever less with duty cycle of 1.5 hours “ON” , 0.5 hour “OFF” at $70\pm 2^{\circ}\text{C}$ ambient.
Low Temperature Storage	Resistance change rate must be in $\pm(5\%+0.05\Omega)$, and no mechanical damage.	IEC 60068-2-1 (Aa) Lower limit temperature , for 2H.
High Temperature Exposure	Resistance change rate must be in $\pm(5\%+0.05\Omega)$, and no mechanical damage.	MIL-STD-202 108A Upper limit temperature , for 16H.

11. Packing

11.1 Tapes in Box Packing:

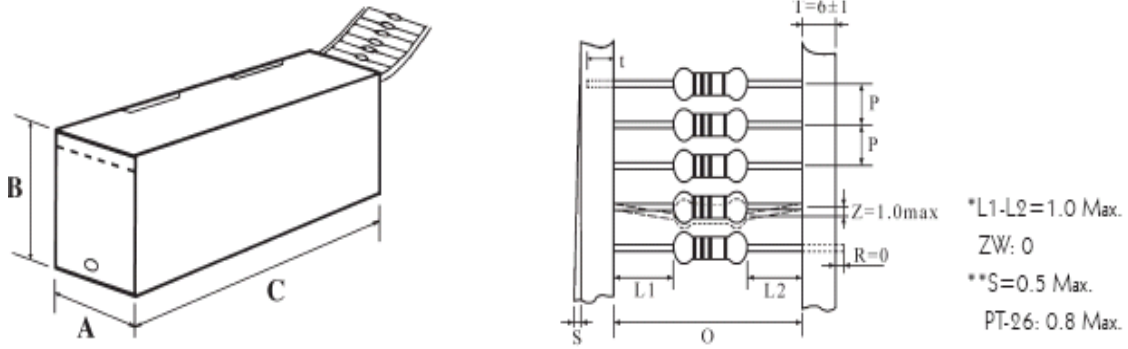

Dimension of T/B (mm)

Part No.	O	P	A±5	B±5	C±5	Qty/Box
KNPA 1/2W	52±1	5±0.3	75	45	255	1,000pcs
KNPA 1WS	52±1	5±0.3	75	45	255	1,000pcs
KNPA 1W	52±1	5±0.3	86	82	255	1,000pcs
KNPA 2WS	52±1	5±0.3	86	82	255	1,000pcs
KNPA 2W	64±5	10±0.5	90	119	255	1,000pcs
KNPA 3WS	64±5	10±0.5	90	119	255	1,000pcs
KNPA 3W	64±5	10±0.5	90	88	255	500pcs
KNPA 5WS	64±5	10±0.5	90	88	255	500pcs
KNPA 5W	90±5	10±0.5	115	124	500	500pcs
KNPA 7WS	90±5	10±0.5	115	124	500	500pcs

11.2 Tapes in Reel Packing:

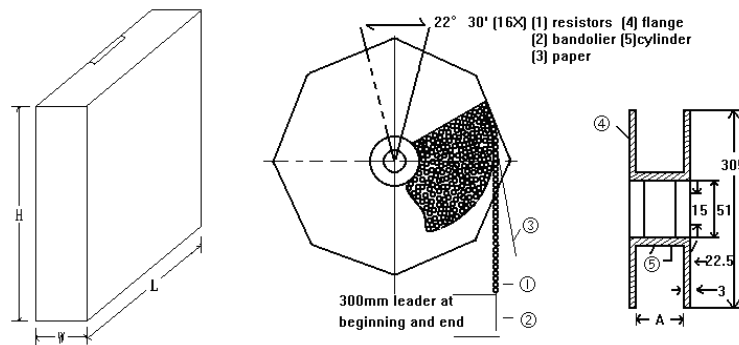

Dimension of Reel (mm)

Part No.	O	A	W±5	H±5	L±5	Qty/Box
KNPA 1/2W	52±1	73±2	85	295	293	2,500pcs
KNPA 1WS	52±1	73±2	85	295	293	2,500pcs
KNPA 1W	52±1	73±2	85	295	293	2,500pcs
KNPA 2WS	52±1	73±2	85	295	293	2,500pcs
KNPA 2W	64±5	80±5	95	295	293	1,000pcs
KNPA 3WS	64±5	80±5	95	295	293	1,000pcs
KNPA 3W	64±5	80±5	95	295	293	1,000pcs
KNPA 5WS	64±5	80±5	95	295	293	1,000pcs
KNPA 5W	90±5	115±5	121	310	310	700pcs
KNPA 7WS	90±5	115±5	121	310	310	700pcs

11.3 Bulk in Box Packing:

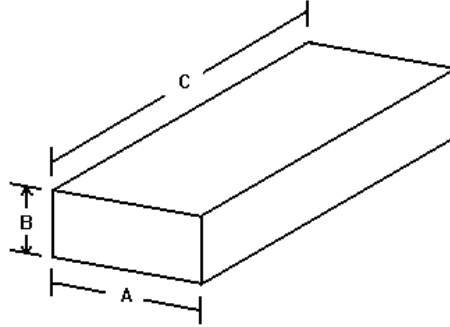

Dimension of Box (mm)

Part No.	A \pm 5	B \pm 5	C \pm 5	Qty/Box
KNPA 1/2W	140	80	240	250/5,000pcs
KNPA 1WS	140	80	240	250/5,000pcs
KNPA 1W	140	80	240	100/2,500pcs
KNPA 2WS	140	80	240	100/2,500pcs
KNPA 2W	140	80	240	100/1,500pcs
KNPA 3WS	140	80	240	100/1,500pcs
KNPA 3W	140	80	240	100/1,000pcs
KNPA 5WS	140	80	240	100/1,000pcs
KNPA 5W	140	80	240	25/400pcs
KNPA 7WS	140	80	240	25/400pcs
KNPA 7W	140	80	240	25/300pcs
KNPA 8WS	140	80	240	25/300pcs
KNPA 8W	140	80	240	25/200pcs
KNPA 9WS	140	80	240	25/200pcs
KNPA 9W	140	80	240	25/200pcs
KNPA 10WS	140	80	240	25/200pcs

12. Note

- 12.1. UNI-ROYAL recommend products store in warehouse with temperature between 15 to 35°C under humidity between 25 to 75%RH.
Even under storage conditions recommended above, solder ability of products will be degraded stored over 1 year old.
- 12.2. Cartons must be placed in correct direction which indicated on carton, otherwise the reel or wire will be deformed.
- 12.3. Storage conditions as below are inappropriate:
 - a. Stored in high electrostatic environment
 - b. Stored in direct sunshine, rain, snow or condensation.
 - c. Exposed to sea wind or corrosive gases, such as Cl₂, H₂S, NH₃, SO₂, NO₂, Br etc.

13. Record

Version	Description	Page	Date	Amended by	Checked by
1	First version	1~8	Mar.20, 2018	Haiyan Chen	Nana Chen
2	1.Modify the Derating Curve	4	Feb.23, 2019	Haiyan Chen	Yuhua Xu
	2. Add the Pulses Energy Curve and Pulses Voltage Curve	5			
	3. Modify characteristic	6~7			
3	Modify the Paint color	5	Jun.24, 2019	Haiyan Chen	Yuhua Xu
4	Modify the size of 8W to 10WS wires from "0.75" to "1.00"	4	Mar.15, 2022	Haiyan Chen	Yuhua Xu
5	Modify the temperature coefficient test conditions	6	Oct.28, 2022	Haiyan Chen	Yuhua Xu
6	1. Modify the marking identifier	3	Jul.27, 2023	Haiyan Chen	Yuhua Xu
	2. Cancel Surge Rating	4			
7	1.Increased standard color code system	3	Apr.01, 2024	Haiyan Chen	Yuhua Xu
	2.Add the 1% tolerance	3~4			